

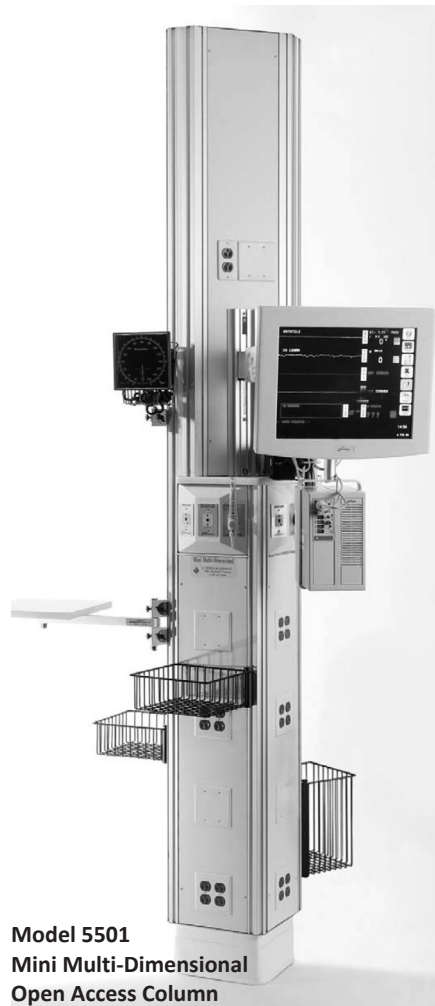

OPEN ACCESS COLUMN

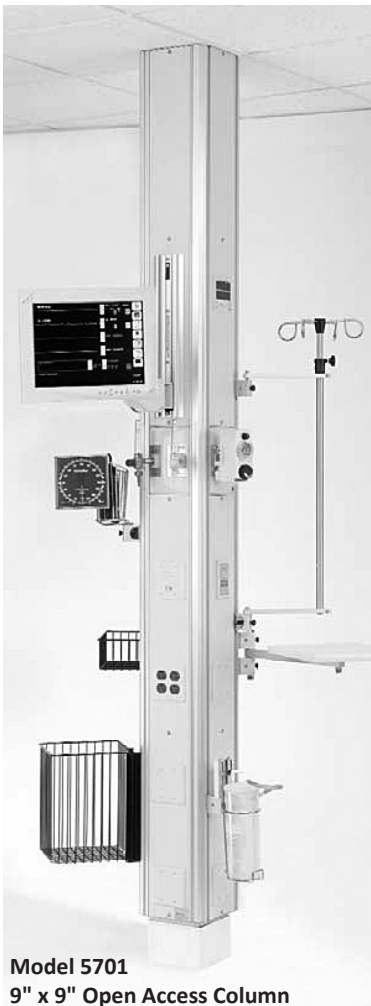

OVERVIEW

The Open Access Column is a UL-listed, multi-sided, vertical hospital modular service assembly. This system uses vertical component chases to conveniently locate medical gas, electrical and communications services, as required.

Vertical accessory tracks are an integral part of the column assembly and are included on each corner, as detailed in the equipment elevation drawings. The interior of the track is easily accessible from the front for cleaning. Vertical accessory mounting tracks are capable of accepting adapters throughout their entire length.

UNPACKING AND INSPECTION

1. Upon receipt of Open Access Column units and prior to unpacking, inspect shipping containers for damage. Document any damage found and notify the carrier and Modular Services Company.
2. Clear a large work area near the location where the unit is to be installed.
3. Locate the carton for the unit you wish to install. Labels at each end of the carton identify the unit type and general description of contents, as well as the room number or area of installation (if applicable).
4. Place the appropriate cartons face down on the floor.
5. Carefully open each carton. Dispose of all excess packaging material, leaving cardboard under the unit to protect the face during installation.
6. Inspect units for defects in materials or workmanship prior to installation. It is the responsibility of the customer to report any damage or deficiencies to Modular Services immediately upon discovery.
7. Review final approved shop drawings and submittal booklet. These documents will provide you with technical details specific to your installation, such as:
 - Wiring diagrams
 - Equipment types and quantities
 - Shop drawings of each type unit
 - Room numbers and location in the building (if applicable)

UNIT INSTALLATION

Base Attachment

1. Locate the column base angle (Figure 1) or 12-gauge galvanized steel angles (packaged separately) at the location where the column is to be mounted.
2. Anchor the base angle to the floor through the holes provided, using two 1/2" diameter Hilti Kwik Bolts or approved equivalent fasteners.
3. Remove one of the 1/4" aluminum plates from the side of the column base (Figure 2).

Figure 1.

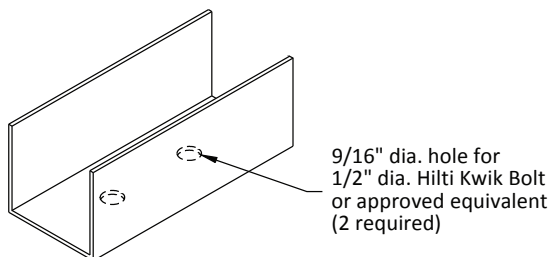
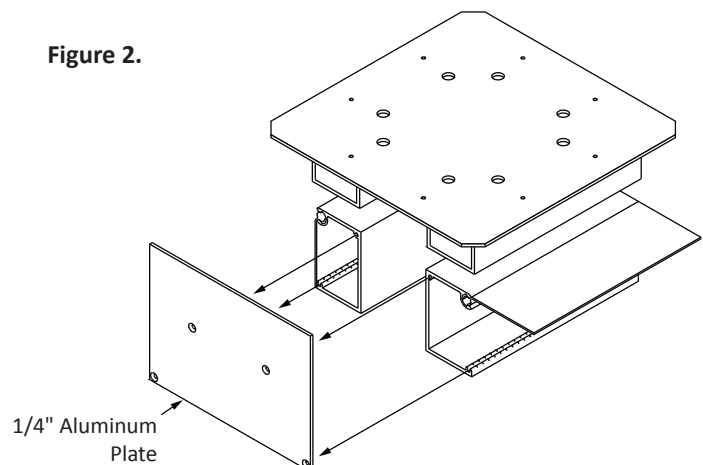

Figure 2.



4. Slide the column base over the base angle mounted to floor (Figure 3).
5. Reattach the 1/4" aluminum plate to the column base.
6. Adjust the unit to the appropriate height and level the column using the height adjustment bolts. These bolts can be accessed by lifting the hinged door on the column base (Figure 4).
7. After the column has been adjusted for height and leveled, secure the column to the base mounting angle using eight #12 Tek screws (Figure 4).
8. A formed Kydex® base cover is supplied for use around the base once all anchorage is complete.

Figure 3.

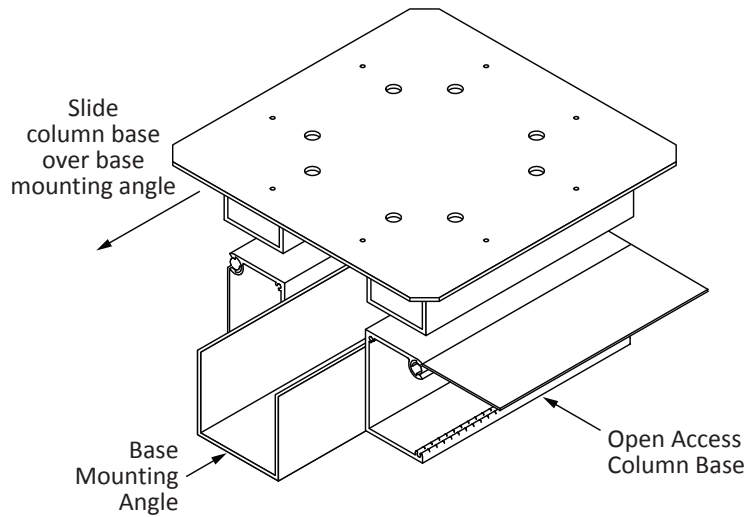
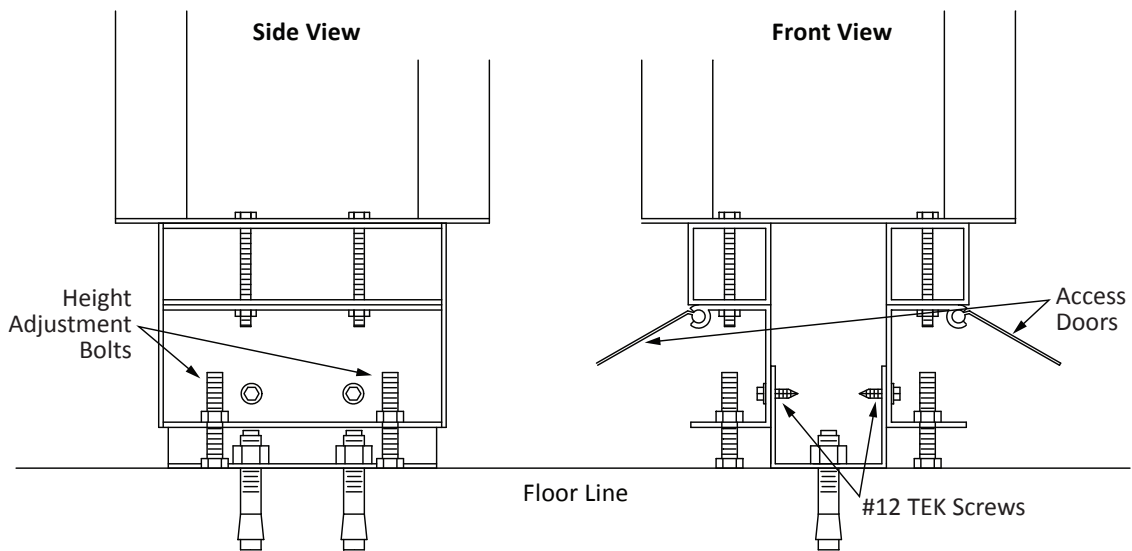

Figure 4.



Ceiling Attachment

NOTE: These instructions pertain only to the anchorage of the unit to the building structure. The structural engineer of record is to verify that the structure is adequate to support all loads the equipment imparts to it.

Adequate support structure above the ceiling line is to be supplied by others by attaching Unistrut, Kendorf, or other suitable bracing (provided by others) to the steel brackets on top of the column and securing the bracing to the building structure (see Figure 5 for suggested means of support).

Figure 5.

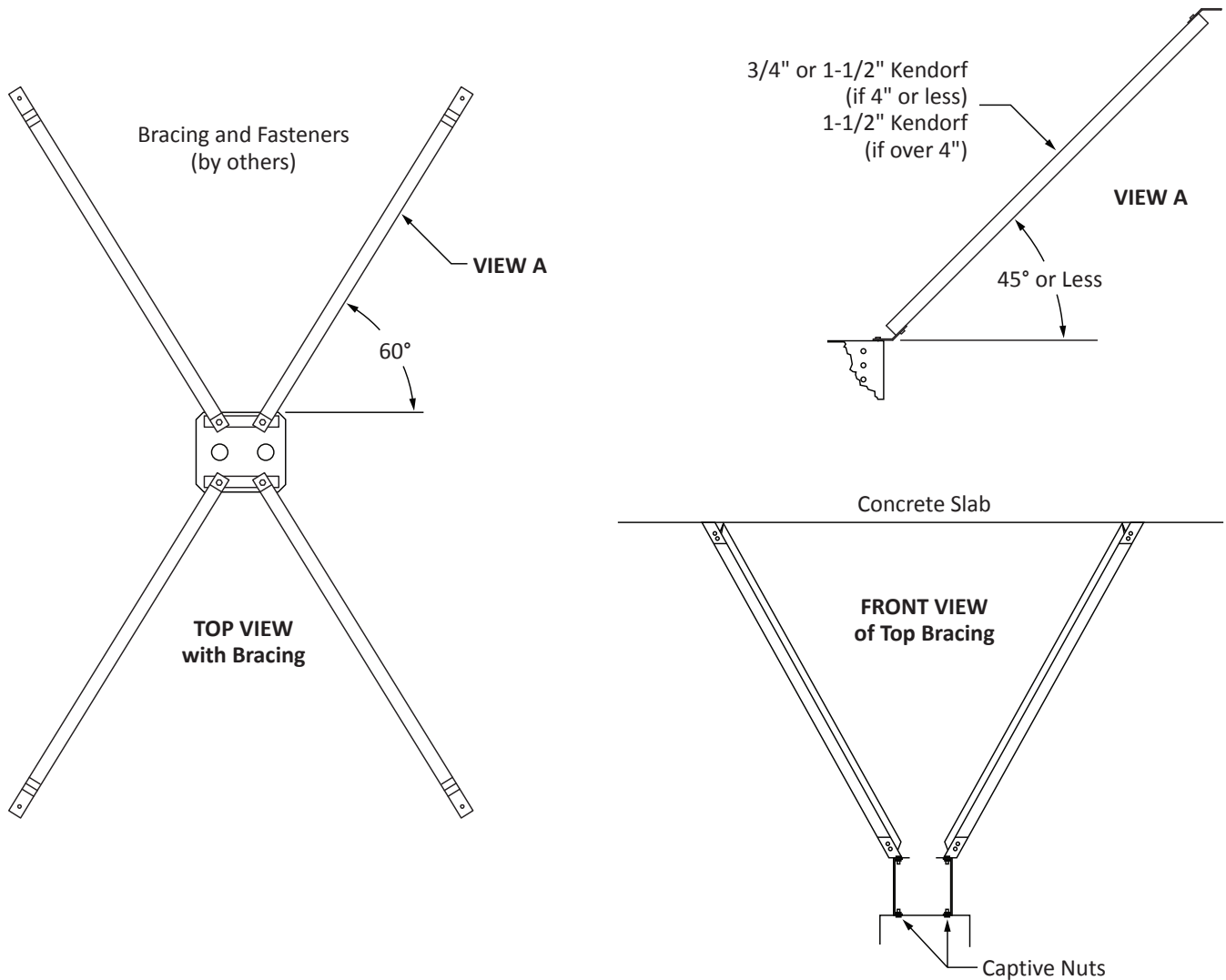

MEDICAL GAS SERVICE CONNECTIONS

1. Use extreme care in making medical gas service connections.
2. Each single-point connection has been provided with a color-coded medical gas label.

Medical gas systems provided by Modular Services have been cleaned, purged, brazed, blown down, labeled, and tested for cross connections and leaks in accordance with the most recent edition of NFPA 99. They are certified to be compliant to all of these requirements and to be leak free. The medical gas system installer is responsible for connecting this manufactured assembly to the pipeline in compliance with all applicable sections of the latest edition of NFPA 99.

During the process of connection to the pipeline there are multiple potential sources of contamination or damage to seals which could result in leaks. First, although Modular Services takes care to protect the ends of our piping system and the openings of station inlets/outlets to avoid contamination, it is at this point that these contamination prevention measures must be removed which exposes the system to the construction environment. Secondly, instrumentation must be inserted into the station inlets/outlets to properly purge the system while it is being brazed in accordance with the requirements of NFPA 99. Lastly, station inlet/outlet front body assemblies (if product is shipped with them installed), which are only rated to a maximum of 100 PSI, must be removed to conduct the initial pressure test which is required to be conducted at a minimum of 150 PSI. After this test is complete the front bodies must be reinstalled to conduct the standing pressure test.

In accordance with NFPA 99 section 5.1.12.2, the installer is required to test the distribution piping in its entirety, which includes the medical gas manifolds provided by Modular even though they have been pretested at the factory. Because of the multiple potential sources of contamination or damage to seals listed above, the installer is to be held responsible for repairing or replacing any seals which have been contaminated or damaged as a result of the process of connecting to the pipeline. The installer shall also be responsible for protecting the station inlets/outlets against contamination after the factory protection has been removed.

Modular Services warrants all defects in piping materials, brazed joints, and workmanship but cannot warrant leaking seals once the factory provided contamination prevention materials are removed from either the end of the piping or the station inlet/outlet.

ELECTRICAL SERVICE CONNECTIONS

1. Ensure all electrical power circuits are locked off prior to connection.
2. Review wiring diagram or shop drawings.
3. All connections are labeled at the point of connection.
4. Make all electrical service and ground connections according to wiring diagram, being careful to observe labeling at service connection.

IMPORTANT: Service connections are to be made and tested in accordance with the National Electrical Code, in addition to any other state and local codes.

LOW-VOLTAGE PROVISIONS

Provisions have been made for the installation of such items as nurse call, code blue, telephone outlets, television outlets, heart monitor outputs, etc., according to the project drawings. These devices are to be mounted directly to the component backboxes and over the decorative panel. Removal of the decorative panel is not required for installation of equipment by others.

OPTIONAL PATIENT MONITOR BRACKET

Slide the monitor bracket into the pre-installed channel (Figure 6).

NOTE: The pre-installed channel is designed to hold monitors weighing 80 pounds or less. Be sure to securely fasten the monitor to the patient monitor bracket.

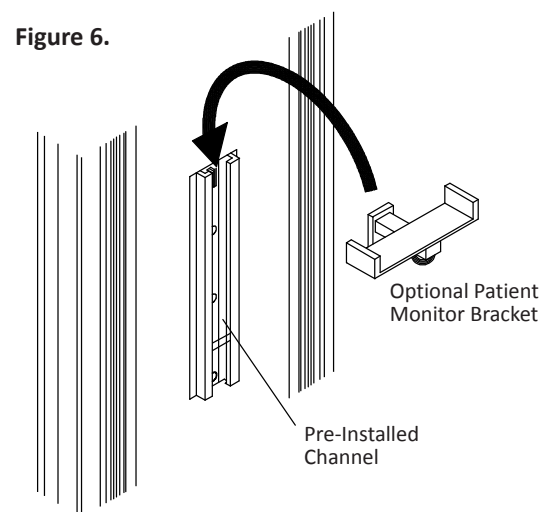

CARE AND MAINTENANCE

1. Clean with mild detergent and warm water. **Do not use lubricants or oils on unit.**
2. Avoid excessive moisture build-up, as it can damage mechanisms in the unit.
3. Disinfect as required with disinfectant approved by the Environmental Protection Agency.
4. To remove difficult spots or stains, use standard household cleansers and a soft-bristled brush.
5. For parts or repairs, contact your sales representative.

INSTALLATION TERMS AND CONDITIONS

Each Modular Services unit, or unit section, shall be completely pre-wired for normal, emergency and low voltage according to the approved submittal. Communication devices and wiring shall be supplied by others. These devices include nurse call, television, code blue, telephone, monitor jacks, etc.

The customer shall be responsible for all electrical conduits (above the junction boxes), wiring hook-up of electrical services, and if applicable, interconnect wiring between sections. All hardware light fixtures shall be installed, wired and lamped by contractor. After installation is complete, the customer shall test equipment functions, as well as electrical receptacles and ground, in accordance with the National Electrical Code.

Medical gas contractor shall be responsible for piping and hook-up of all medical gas services. The medical gas contractor shall be responsible for purging, pressure testing, gas identification, and system certification in accordance with NFPA 99.

Modular Services Company shall have no responsibility or liability for delays, however caused. Owner shall hold Modular Services harmless from damages or injury related to any failure or neglect of owner, its employees, agents or licensees. Modular Services shall not be liable for consequential damages; makes no warranties, expressed or implied; and assumes no obligation other than those expressly contained herein.

WARRANTY

Modular Services Company warrants that all equipment assemblies shall be free from defects in material and workmanship for a period of 12 months from date of the owner's acceptance to the installing contractor or the date the equipment is put into service, whichever comes first. Warranty excludes electric lamps and/or any material not furnished by Modular Services. Warranty does not cover damage due to improper installation and/or abuse.

It is the responsibility of the customer to report any noted product deficiencies to Modular Services immediately upon discovery. It is the responsibility of Modular Services to expediently resolve the discrepancy. Any modification made to the product without the written authorization from Modular Services will void this warranty.

Also, in the event product modifications or repairs are made without the written consent of Modular Services, Modular Services shall not be held liable for any cost associated with the modification or repair.

There are no warranties of fitness which extend beyond the description on the face hereof.



MODULAR
SERVICES COMPANY

500 E. Britton Rd. • Oklahoma City, OK 73114
Tel: 800.687.0938 • Fax: 405.528.0368
www.modularservices.com
info@modularservices.com